**HOW MICROPROCESSOR RELAYS RESPOND TO
HARMONICS, SATURATION, AND OTHER WAVE
DISTORTIONS**

STANLEY E. ZOCHOLL

**SCHWEITZER ENGINEERING LABORATORIES, INC.
PULLMAN, WASHINGTON USA**

GABRIEL BENMOUYAL

**IREQ
VARENNES, QUEBEC CANADA**

Presented before the

**24th ANNUAL
WESTERN PROTECTIVE RELAY CONFERENCE
SPOKANE, WASHINGTON
OCTOBER 21-23, 1997**

HOW MICROPROCESSOR RELAYS RESPOND TO HARMONICS, SATURATION, AND OTHER WAVE DISTORTIONS

Stanley E. Zocholl
Schweitzer Engineering Laboratories, Inc.
Pullman, WA USA

Gabriel Benmouyal
IREQ
Varenes, Quebec CANADA

ABSTRACT

The magnetics and mechanisms of electromechanical relays are difficult to formulate, and their characteristics are obtained mainly from experimental test data. As a result, exactly how relays respond, or should respond, to harmonics, saturation, and wave distortion in general has been a source of discussion, controversy, and anxiety for the relay engineer. In contrast, microprocessor relays execute algorithms that are mathematical procedures. They produce analytic characteristics that can be described accurately by an equation. We therefore have the opportunity to calculate the response to specified waveforms. The key to the behavior of microprocessor relays is in calculating the response of the digital filter and comparing the deviation of the response to the ideal sine-wave signal. This paper presents the response of microprocessor relays to such waveforms as the third-harmonic distortion in distribution neutral current, six-pulse rectifier current waveforms with resonance, transformer magnetizing inrush current, and false differential current in ring bus CTs caused by unequal remanence. Taken together, these examples provide a background to discuss the philosophy of ideal response and draw conclusions as to the degree of tolerance to wave distortion.

INTRODUCTION

What do relays measure? Electromechanical relays produce torque that is proportional to the square of the flux produced by current. These relays respond to the current squared or to the product of the currents produced by the input quantities. Since root-mean-square (rms) is defined as the average of the integral of the square of the current, these relays are said to be rms responsive. Solid-state analog relays, utilizing linear circuits and level detectors, respond to the peak of the input signal. Where microprocessor relays can implement either of these techniques, most microprocessor relays use digital filters to extract only the fundamental and either attenuate or eliminate harmonics.

Which technique is best? Protective relays are designed for 60 hertz sine-wave operation, and all perform reliably in the absence of significant wave distortion. Even with the growing base, the nonlinear loads of pulse rectifiers, variable speed drives, and uninterruptible power supplies, the wave distortion must be severe before a distinction can be made. This paper investigates the severe cases of third-harmonic distortion in distribution neutrals, pulse rectifier current waveforms with harmonic resonance, transformer magnetizing inrush current, and false differential current in ring bus CTs caused by remanence. Collectively, these examples provide the background to discuss the philosophy of ideal response and draw conclusions as to the degree of tolerance to wave distortion.

THE DIGITAL FILTER

Microprocessor relays execute mathematical procedures and produce analytic characteristics that can be described accurately by equations. We therefore have the opportunity to calculate relay response to any specified waveform. The key to the behavior of microprocessor relays is the output of the digital filter. This is obtained by sampling sine-wave currents and/or voltages at discrete time intervals. A fixed number of instantaneous samples per cycle are converted to digital quantities by an A/D converter and stored for processing. Digital filtering is the simple process of multiplying the successive samples by predetermined coefficients and then combining them to obtain digital quantities representing the phasor components of the input. For example, a first sample taken at an arbitrary time on a current sine wave is the instantaneous dc value representing $I \cos(\omega \cdot t + \theta)$, where θ is an arbitrary phase angle. A second sample taken 90° later is $I \sin(\omega \cdot t + \theta)$. Consequently, just taking two samples 90° apart extracts the real and imaginary components of a phasor.

The term "filtering" is used because the magnitude of the components change when the sampling interval remains fixed, and the input frequency is varied. The filter output then varies in magnitude and phase as a function of the input frequency. Consequently, more than two samples per cycle are used, and filter coefficients are selected to obtain a favorable frequency response. For example, a 16 sample/cycle full cycle cosine filter^[1] is particularly suited for protective relaying. While extracting the fundamental, the filter rejects all harmonics including the decaying exponential and will be used in the subsequent cases. The filter in equation form appears as follows:

$$\text{The filter coefficients} \quad \text{CFC}_n = \cos\left[\frac{2\pi}{16} \cdot n\right] \quad (1)$$

$$\text{The Cosine filter} \quad \text{IX}_{\text{smp}l+\text{s}pc} = \frac{2}{N+1} \sum_{n=0}^N \text{I}_{\text{smp}l+\text{s}pc-n} \text{CFC}_n \quad (2)$$

$$\text{The phasor magnitude} \quad |\text{Io}|_{\text{smp}l+\text{s}pc} = \sqrt{\left(\text{IX}_{\text{smp}l+\text{s}pc}\right)^2 + \left(\text{IX}_{\text{smp}l+\text{s}pc-\frac{\text{s}pc}{4}}\right)^2} \quad (3)$$

$$\text{The phasor output} \quad \text{Io}_{\text{smp}l+\text{s}pc} = \text{IX}_{\text{smp}l+\text{s}pc} + j \cdot \text{IX}_{\text{smp}l+\text{s}pc-\frac{\text{s}pc}{4}} \quad (4)$$

where: $N = 15$
 $n = 0, 1, 2, \dots, N$
 $\text{smp}l = \text{sequence of samples } 0, 1, 2, 3, \dots$
 $\text{s}pc = \text{number of samples per cycle (16)}$
 $\text{I}_{\text{smp}l+\text{s}pc-n} = \text{Current samples}$
 $\text{IX}_{\text{smp}l+\text{s}pc} = \text{Filter output}$
 $\text{Io} = \text{filter derived current phasor}$

In equation (2), any value of $\text{smp}l$ indicates that 16 samples of the current have been stored. The index n ranges from 0 to 15 to apply the coefficients and sum the samples to produce the output. With 16 samples/cycles, 4 samples represent 90° electrical degrees. Therefore, in equation (4), the present output together with the output recorded four samples before constitute the real and

imaginary components of the phasor. Annex A is a Mathcad® 6.0 file that implements the cosine filter and allows the user to investigate its response to an offset fault current.

The Effect of Lightning on Instantaneous Relays

What need is there for filtering in protective relays? In June 1995, lightning hit a 734 kV line on Hydro Quebec's main transportation grid. An instantaneous relay in the primary protection tripped the line. As a result, a study was conducted to evaluate the effect of lightning on the instantaneous relays. A sample of the current due to a lightning stroke was obtained from the EMTP program by exciting the line with a voltage pulse. The current samples divided by the CT ratio are shown in Figure 1, where the sampling frequency is 20 kHz. Figure 2 shows the FFT plot of the current waveform, where the dominant frequencies at 400 and 800 are dependent on the parameters of the line.

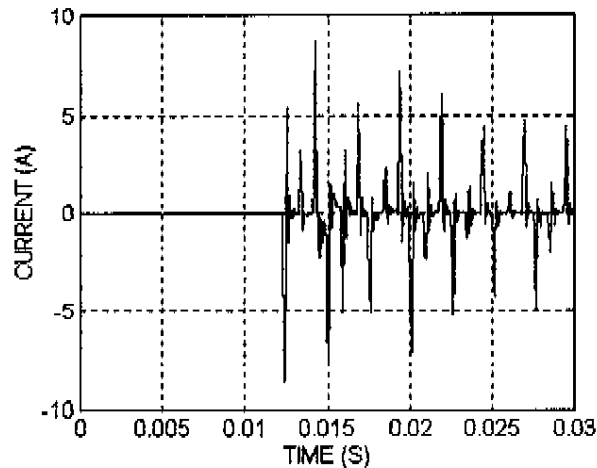

Figure 1: Current Samples Due to Lightning

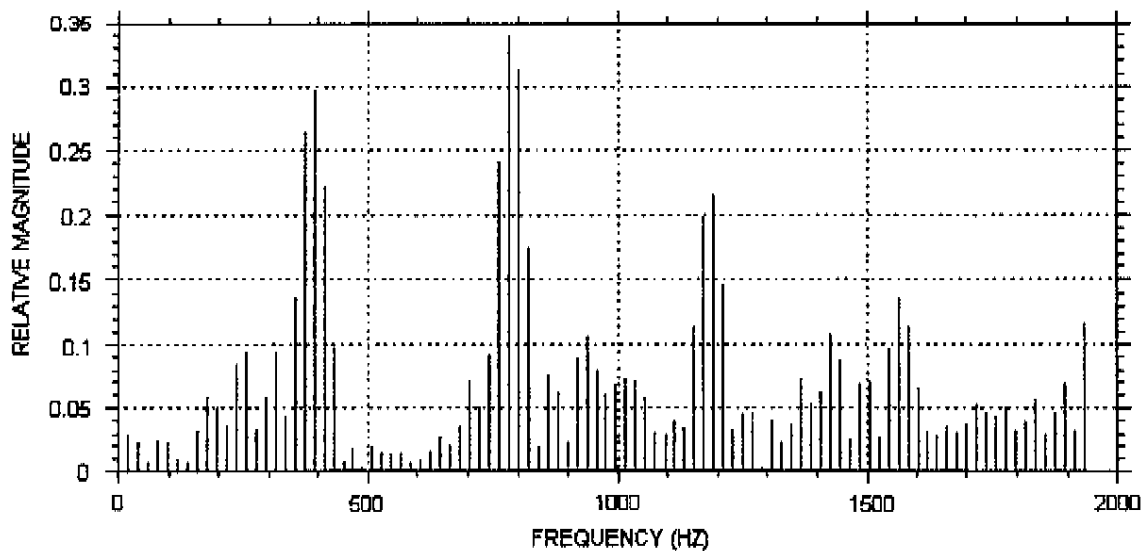

Figure 2: FFT of Current Samples

Using the SPICE program, the samples were applied to a model of the major circuit components of two solid-state instantaneous relays A, and B, designed in the early 60's. The type of interposing CT output burden had a paramount effect on the overall relay performance.

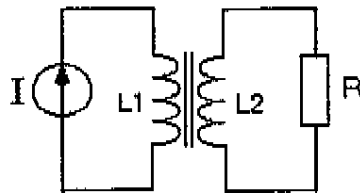

Figure 3: Interposed Current Transformer

From the schematic of the interposing transformer shown in Figure 3, the voltage across the burden can be characterized as:

$$V_b = \frac{s \cdot M \cdot R \cdot I(s)}{R + L2 \cdot s} \quad \text{where } M = \sqrt{L1 \cdot L2} \quad (1)$$

In Relay A, the transformer output impedance is much greater than the burden, and the output is:

$$V_b = \frac{s \cdot M \cdot R \cdot I(s)}{R + L2 \cdot s} = \sqrt{\frac{L1}{L2}} \cdot R \cdot I(s) = \frac{R \cdot I(s)}{n} \quad (2)$$

where n is the turns ratio. In Relay B, the burden impedance is much greater than the transformer impedance, and the output is:

$$V_b = s \cdot M \cdot I(s) \quad (3)$$

In Relay B, the burden is a differentiator used to reject the dc component in the fault current to minimize overreach. However, its gain causes a drastic decrease in the pickup with frequency as shown Figure 4.

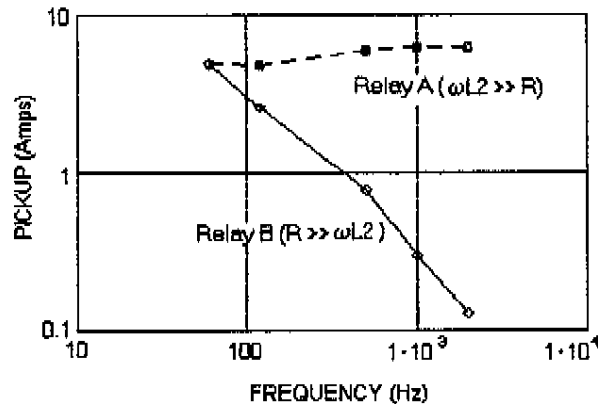

Figure 4: Pickup Current Versus Frequency

Both relays are peak detectors and have the frequency response to respond to the lightning-induced current. Figure 5 shows the response of Relay A to the lightning-induced current. Although both relays were designed for operation at the nominal frequency of the power system, no provision is made to cope with common high-frequency phenomenon.

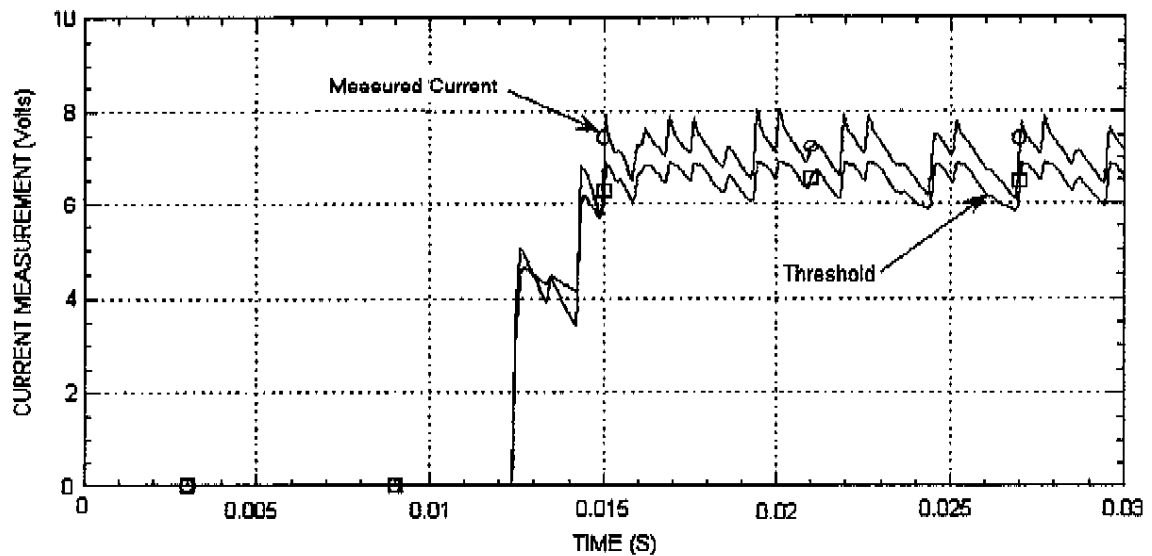

Figure 5: Measurement of Lightning Current by Relay A

In contrast, it is standard practice in microprocessor relaying to use a digital filter to extract the fundamental and an anti-aliasing filter to attenuate the high frequency to preserve the measurement. For comparison, the lightning samples were applied to a theoretical digital relay using a fourth order Butterworth anti-aliasing filter with a cut-off frequency of 480 Hz and a 16 sample-per-cycle cosine filter. The attenuation of the anti-aliasing filter is shown in Figure 6. Figure 7 shows the small magnitude extracted by the cosine filter.

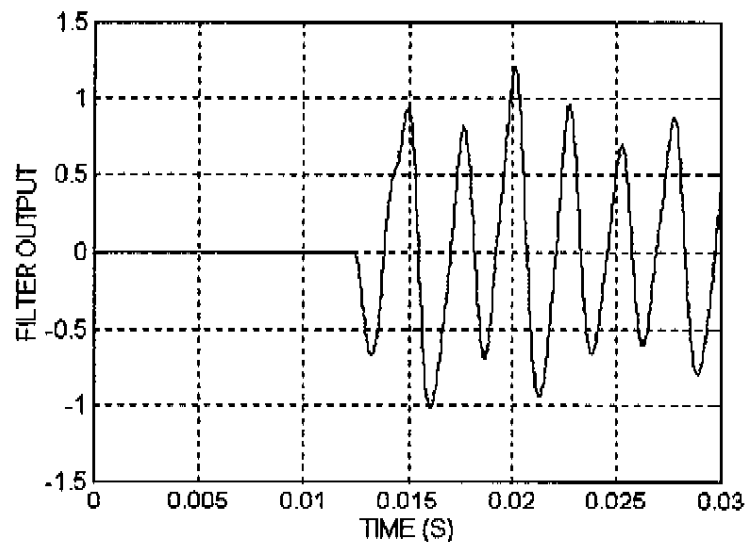

Figure 6: Response of the Anti-Aliasing Filter to Lightning

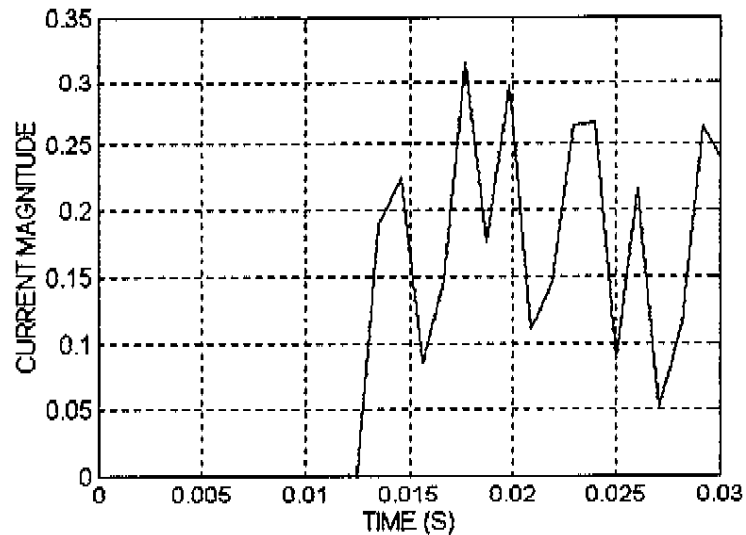

Figure 7: Digital Filter Response to Lightning

Neutral Third Harmonic

Ground overcurrent relays operate in an ambient of the residual caused by predictable normal load unbalance and uncertain amounts of harmonics accumulated in the neutral. The harmonic distortion may be due to magnetizing current accumulation from distribution transformers or to the poor practice of paralleling small solidly grounded generators. Therefore, ground relays must be set low enough to provide sensitive ground fault protection and high enough to avoid nuisance trips. The response of the digital filter to a neutral current consisting of 50 amperes of fundamental with 100 amperes of third-harmonic is shown in Figure 8. In this case, you have to set an electromechanical, or a solid-state ground overcurrent relay, above 112 amperes rms. However, as shown in Figure 8, the digital filter acquires only the fundamental, allowing a more sensitive setting. It is clear in this case that the fundamental contains the information, and everything else interferes.

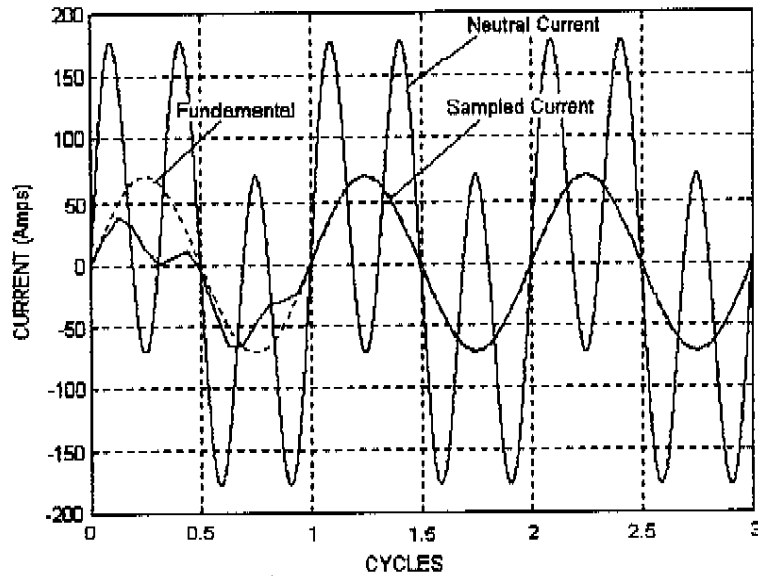

Figure 8: Filter Response for Neutral Current With Third-Harmonic Distortion

Harmonic Distortion in Pulse Rectifiers

Table 1, quoted from Reference [4], lists the nontriple harmonics introduced by a six-pulse rectifier. The first column lists the magnitude of the harmonics typical for inductive normal load. The second column lists the magnitudes, with resonance near the seventh harmonic, caused by power factor correction capacitance. The IEEE std 519-1992 defines the distortion factor as the ratio of the root-mean-square of the harmonics to the root-mean-square of the fundamental, expressed as percent of the fundamental. The factor of 21% indicates a severely distorted waveform. However, it poses no particular difficulty for a relay measuring rms, peak, or the fundamental because the total root-mean-square is only 1.02 times that of the fundamental. Figure 9 shows the waveform, with the fundamental shown as a dotted line. It also shows the fundamental acquired by the digital filter.

The resonant waveform poses a dilemma. The voltage drop caused by the six-pulse rectifier current flowing through the incoming source impedance causes a voltage drop containing the harmonics. Consequently, the voltage at the plant bus then contains the nontriple harmonics. Unfortunately, the capacitance required to effectively correct the plant power factor forms a series resonant circuit with the inductance in the source impedance with a resonant frequency between the fifth and the seventh harmonic supplied by the rectifier. The resulting resonant waveform is shown on Figure 10.

Table 1: Harmonics in a Six-Pulse Rectifier

Harmonic Order	Six-Pulse Rectifier Magnitude	Magnitude with Resonance
1	100.0%	100.0%
5	17.4%	45.0%
7	11.0%	150.0%
11	4.5%	9.0%
13	2.9%	5.0%
17	1.5%	3.0%
DF	21%	157%

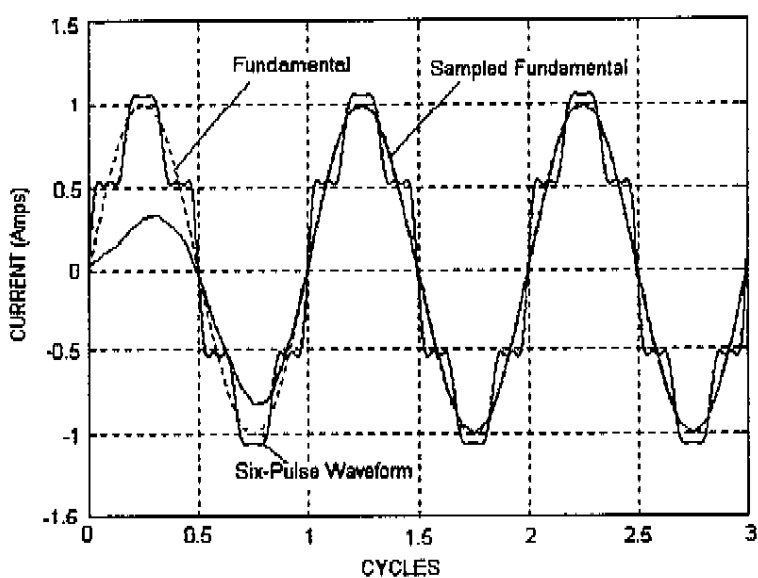

Figure 9: Digital Filtering and Fundamental of a Six-Pulse Rectifier Current

The waveform on Figure 10 has a distortion factor of 156% and rms of 186% of the fundamental. It is the practice in industrial plants to set overcurrent relay pickup at 120% to 150% of normal load current. Consequently, either the peak-responsive or the rms-responsive relay will trip and cause a plant outage for a condition that must be tolerated until diagnosed and remedied [5]. Raising the pickup setting can prevent the trip but upsets the coordination. The digital filter has a distinct advantage in this case as shown in Figure 10. Consequently, the fundamental responsive relay requires no setting adjustment and conserves the intended coordination.

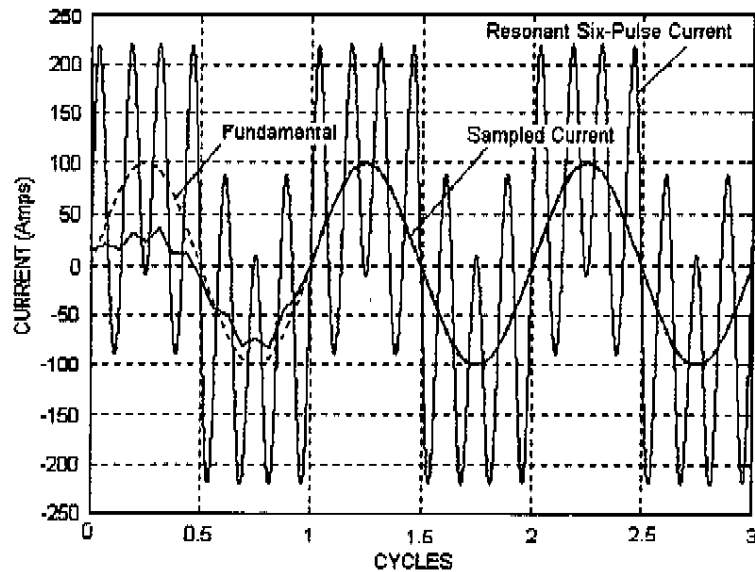

Figure 10: Digital Filtering and Fundamental of Six-Pulse Waveform With Resonance

Inrush Current

You would normally associate the plot of the inrush current shown in Figure 11 with a transformer differential relay with harmonic restraint. It is the inrush caused by energizing a 600 MVA transformer. What makes this plot interesting is that it was obtained from the event report recorded by a distance relay. The event was triggered by a high-set instantaneous element with a six ampere pickup. As part of the unused loss-of-potential logic in the relay, it was programmed to trigger the event report but not to trip. The inrush current plot is made using the event report of unfiltered samples. The plot of the fundamental is made using the event report of samples after filtering. The second-harmonic plot was calculated to show the second-harmonic content of the waveform.

In the cases above, the relaying information is contained in the system fundamental, and the harmonics only interfered. It is somewhat surprising that the digital filter will faithfully extract the fundamental from any waveform that is periodic at system frequency. The distance elements did not operate because no voltage depression accompanied the high current signal. However, sensitive settings caused the negative-sequence directional to identify a forward fault^[6].

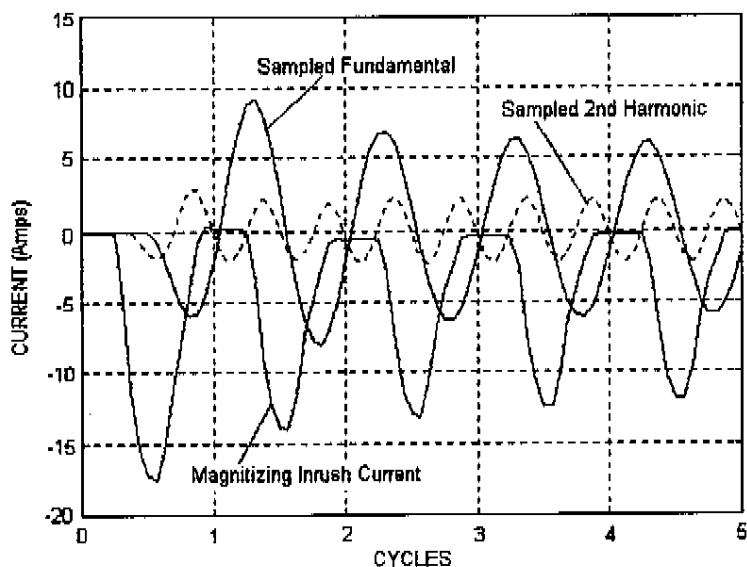

Figure 11: Transform Inrush Current

Totalizing CTs in a Ringbus

What could be more common than the ringbus configuration shown in Figure 12? At the same time, what could be more nebulous than the level of the remanent flux in the CTs? The CTs secondary currents add for line faults fed from the breakers and subtract for current flowing around the loop to produce zero current in the relays. The adequately rated redundant sets of C800, 2000:5 CTs have no more than a 1.5 ohm burden. How effective is the cancellation?

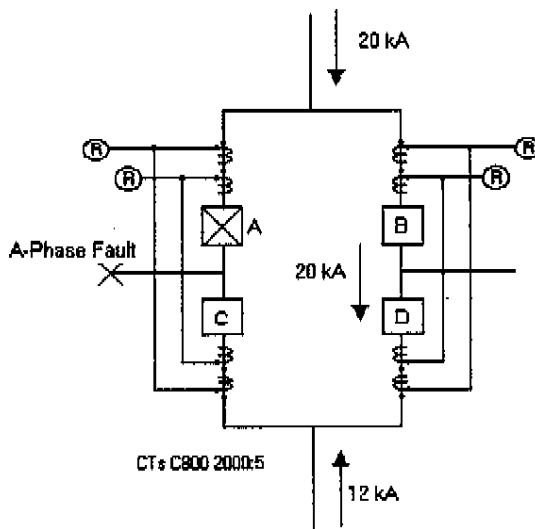

Figure 12: Ringbus Fault

Consider the case where Breakers A and C have tripped to clear a 20,000 ampere fault on the west line shown in the diagram. Closing Breaker C back into the fault causes an instantaneous trip of Breakers B and D on the east line. The relay event reports recorded 6000 amperes from

one set of CTs and 2000 amperes from the other, where the relay pickup settings were 800 amperes for the ground element and 2000 amperes for the phase element. The unequal response indicates the presence of remanent flux.

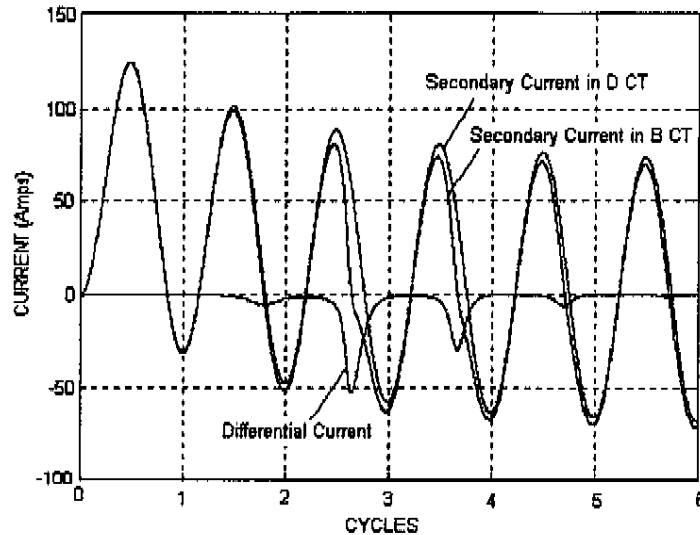

Figure 13: Secondary Currents in B and D for 20 kA Asymmetrical Fault

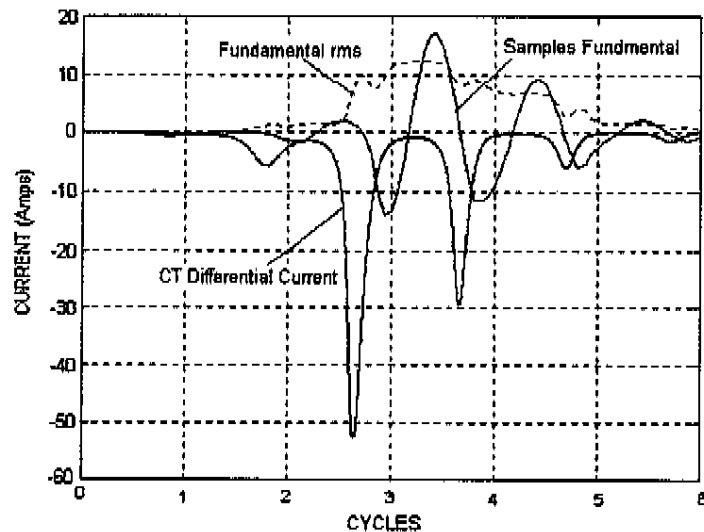

Figure 14: Differential Current and Sampled Fundamental

Consider that for faults on the line the current divides equally in the breakers. The high current fault in each CT has the same polarity and contributes to a remanent flux of the same polarity in each CT. Fault current flowing in the loop causes a flux that adds to the remanent flux in one CT to promote saturation and subtracts from the flux in the other to prevent it. Figure 13 shows the CT secondary current at breakers B and D for the 20 kA asymmetrical fault. The differential current is caused by the momentary saturation^[8] of the one CT that has remanent flux equal to 20% of the saturation flux density. Figure 14 shows the differential current that caused the outage and the fundamental acquired by the relay's digital filter.

The problem occurs near generation where the fault current is ten times the CT rating. To avoid the problem, set the pickup of instantaneous elements to not less than half the maximum fault current, or use time delays for more sensitive settings.

CONCLUSIONS

1. Electromechanical and analog relay characteristics are known through experiment. Microprocessor relay characteristics are known through equations that provide the means to calculate their response.
2. Where classical relays respond to the root-mean-square or to the peak of the input signal, most microprocessor relays respond to the fundamental.
3. Microprocessor relays employ a digital filter to extract the fundamental and an anti-aliasing filter to reject higher harmonics.
4. Root-mean-square, peak, and fundamental responding relays all perform reliably in the absence of significant wave distortion. Distinctions can be made in cases of severe wave distortion.
5. In the majority of the cases, the information is in the fundamental, and harmonics interfere. It is somewhat surprising when the fundamental is extracted from error current, from inrush, or remanent induced saturation in CTs.

ACKNOWLEDGMENT

We wish to thank Mr. Michele Rousseau of the Hydro Quebec Planning Department for supplying the EMTP file of the current waveform due to lightning, which was used in our paper.

REFERENCES

- [1] E. O. Schweitzer III and Daqing Hou, "Filtering for Protective Relay," 19th Annual Western Protective Relay Conference, Spokane, Washington, October 20-22, 1992.
- [2] S. E. Zocholl, Armando Guzmán, and Daqing Hou, "Transformer Modeling as Applied to Differential Relaying," Proceedings of the 22nd Annual Western Protective Relay Conference, Spokane, WA, October 24-26, 1996.
- [3] W. A. Elmore, C. A. Kramer, and S. E. Zocholl, "Effects of Waveform Distortion on Protective Relays." IEEE Transactions on Industrial Applications, Vol. 29, No. 2, March/April 1993, pp. 404-411.
- [4] David E. Rice, "Adjustable Speed Drives and Power Rectifiers Harmonics - Their Effect on Power System Components," IEEE Transactions on Industrial Applications, Vol. IA-22, No. 1, January/February 1986, pp. 161-177.
- [5] S. Bhattacharya, Po-Tai Cheng, and Deepak Devan, "Hybrid Solutions for Improving Passive Filter Performance in High Power Applications," IEEE Transactions on Industrial Applications, Vol. 33, No. 3, May/June 1997, pp. 732-747.

- [6] Jeff Roberts, E. O. Schweitzer III, Renu Arora, and Ernie Poggi, "Limits to the Sensitivity of Ground Directional and Distance Protection," 22nd Annual Western Protective Relay Conference, Spokane, Washington, October 24-26, 1995.
- [7] IEEE Std 519-1992, Recommended Practices and Requirements for Harmonic Control in Electrical Power Systems.
- [8] S. E. Zocholl, Jeff Roberts, and Gabriel Benmouyal, "Selecting CTs to Optimize Relay Performance" 23rd Annual Western Protective Relay Conference, Spokane, Washington, October 15-17, 1996.
- [9] G. Benmouyal, H. Bilodeau, S. Chano, G. Sybille, "New Algorithm for Protection of Capacitor Banks Exposed to Harmonic Overvoltages," IEEE Transaction on Power Delivery, Vol. 10, No. 2, pp. 621-30, April 1995.

ANNEX A

COSFILT.MCD. This Mathcad® 6.0 file applies the digital cosine filter to an asymmetrical fault current and extracts the fundamental of the waveform and its magnitude. The file was written and formulated 4/10/96 by Armando Guzmán of Schweitzer Engineering Laboratories, Inc., Pullman, WA.

Fault duration	$\text{cycles} \equiv 6$	
System frequency	$f \equiv 60$	$\omega := 2 \cdot \pi \cdot f$
Sampling frequency	$f_s \equiv 16 \cdot f$	$f_s = 960$
Samples/cycle	$\text{spc} := \frac{f_s}{f}$	$\text{spc} = 16$
Maximum number of samples	$\text{mns} := \text{spc} \cdot (\text{cycles} + 1)$	$\text{mns} = 112$
Index of samples	$\text{smp1} := 0,1..\text{mns}$	
Time at each sample	$t_{\text{smp1}} := \frac{\text{smp1}}{f_s}$	
Current magnitude	$I1 := 100$	
System R	$R1 := 5$	
System X	$X1 := 200$	
System X over R ratio	$\frac{X1}{R1} = 40$	
System time constant	$\tau := \frac{X1}{2 \cdot \pi \cdot f \cdot R1}$	$\tau = 0.106$
Current phase angle	$\theta := \frac{\text{atan}\left(\frac{X1}{R1}\right)}{\text{deg}}$	$\theta = 88.568$
Incident angle (degrees)	$\phi \equiv -12$	
Sample time interval	$\text{cycle} := \frac{f}{f_s}$	$\text{cycle} = 0.063$
Current equation	$I_{\text{smp1+spc}} := \sqrt{2} \cdot I1 \cdot \left(\sin(\omega \cdot t_{\text{smp1}} + \phi \cdot \text{deg} - \theta \cdot \text{deg}) - e^{-\frac{t_{\text{smp1}}}{\tau}} \cdot \sin(\phi \cdot \text{deg} - \theta \cdot \text{deg}) \right)$	
Window length	$N \equiv 16$	$n := 0..N - 1$

Cosine filter coefficients $CFC_n := \cos\left(\frac{2 \cdot \pi}{spc} \cdot n\right)$

The cosine filter $IX_{ampl+spc} := \frac{2}{N} \cdot \sum_{n=0}^{N-1} I_{ampl+spc-n} \cdot CFC_n$

Phasor amplitude $M_{ampl+spc} := \sqrt{\left(IX_{ampl+spc}\right)^2 + \left(IX_{ampl+spc-\frac{spc}{4}}\right)^2}$

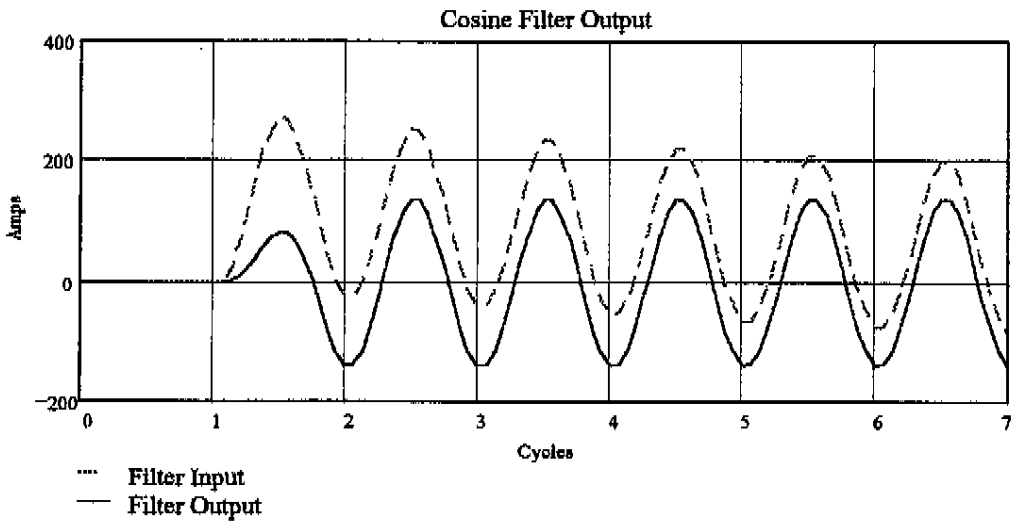
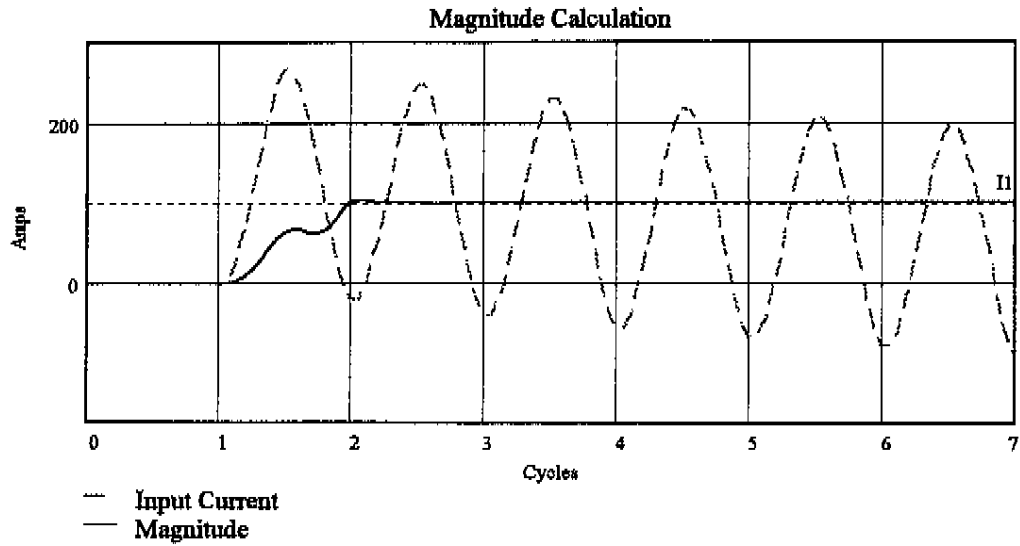

Copyright © SEL 1997
(All rights reserved)
Printed in USA